



**BATCH TYPE BALL MILL**



**YANTRA SHILPA UDYOG PVT. LTD.**

# **CONSTRUCTIONAL FEATURES OF 'YSU' BALL MILL**

- All steel construction.
- Ultrasonic quality Alloy Steel Journal.
- Jig fabricated weldment with low heat input electrodes.
- Stress relived.
- Over sized Heavy duty Spherical Roller Main Bearing.
- Centre Lathe turned.

## **DRIVE SYSTEM**

- Belt driven on Shell.
- Modular Gear Box Unit.
- Fluid Coupling.
- Auxiliary Drive.
- High efficiency Motor and Control Panel.

# QUESTIONNAIRE FOR SELECTION

- Type of grinding – WET or DRY.
- Product name and components.
- Product characteristics like-  
Toxic, Hazardous, Flammable. Corrosive or abrasive.
- Product Physical Characteristics.
- Quantity per batch.
- Bulk Density.
- Product size (Mesh/ Micron)  
Initial- Final.
- Hardness – MOHS Scale.
- Upper temperature limit while grinding.
- Provision of cooling jacket.
- Type and quantity of liquid to be added (In case of Wet Grinding).
- Liquid Viscosity.
- Product contact surface material.
- Specific problem to be considered during grinding.

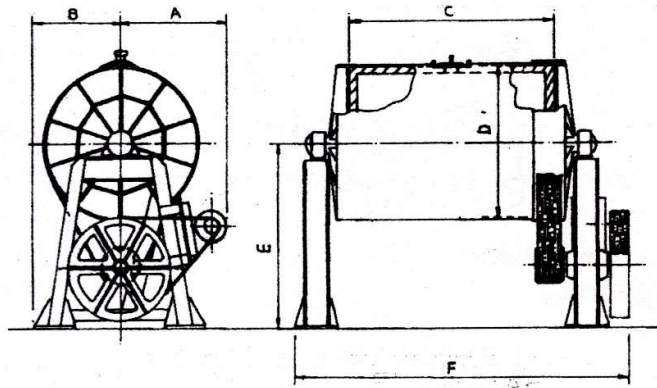

**RD:-1**

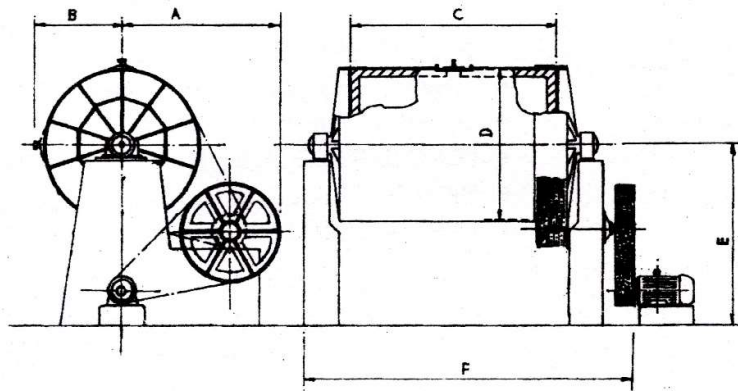

**RD:-2**

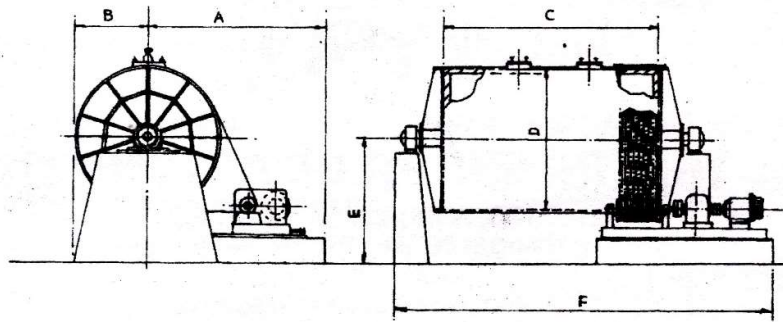

**RD:-3**

DIAGRAM REF		RD-1	RD-1	RD-1	RD-2	RD-2	RD-2	RD-2	RD-3	RD-3	RD-3
		YSU-015	YSU-035	YSU-050	YSU-170	YSU-250	YSU-440	YSU-700	YSU-1000	YSU-1500	YSU-3100
SIZE AND OVERALL DIMENSION, IN mm	A	740	1220	1220	1425	1750	1900	2530	3100	3836	4000
	B	580	750	750	775	850	1000	1200	1320	1420	1750
	C	580	880	880	1180	1480	1776	2076	2372	2960	4150
	D	580	730	880	1330	1480	1780	2080	2368	2568	3160
	E	900	1290	1367	1450	1500	1500	2000	1900	2200	2200
	F	1580	2000	2046	2854	1900	3717	4610	4688	5900	7200
INSIDE NET VOLUME (Lt.)		150	370	535	1640	2540	4420	7000	10450	15330	32500
RPM OF DRUM		40	36	33	26	24	22	19	15	15	12
MAIN MOTOR (H.P.)		2.0	5.0	5.0	10.0	12.5	20.0	40.0	50.0	60.0	125.0
AUXILIARY MOTOR (H.P.)		–	–	–	–	–	–	–	✓	✓	✓
BACK STOP		–	–	–	–	–	–	–	✓	✓	✓
CONCRETE FRAME		–	–	–	✓	✓	✓	✓	✓	✓	✓
STEEL FRAME		✓	✓	✓	✓	✓	–	–	–	–	–

# PRODUCT GALLERY

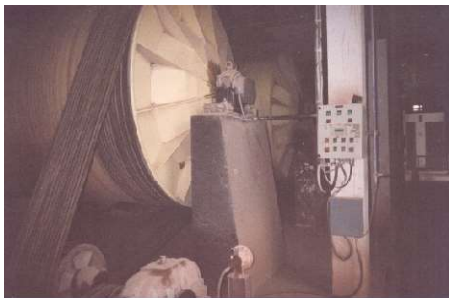
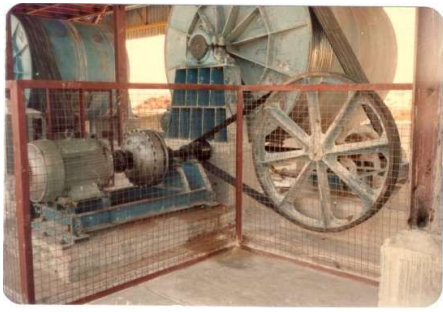

## **SOME OF OUR PROMINENT CUSTOMERS**

- NATIONAL ALUMINIUM CO LTD, DAMONJODI, ORISSA
- SOMANY PILKINGTONS, HARYANA
- H & R. JOHNSON GROUP. MUMBAI
- HINDUSTHAN SANITARYWARES CERA GROUP, BARODA
- EID PARRY, RANIPET
- MURUDESHWAR CERAMICS, HUBLI & KARAIKAL
- KAJARIA CERAMICS, RAJASTHAN
- REGENCY GROUP, YANAM, PANDICHARI
- SPARTEK GROUP, VIJAYWADA
- ORIENT CERAMIC, GAJIABAD, UP
- CARBORANDUM UNIVERSAL, HOSUR. KARNATAKA,
- TATA CERAMICS, QUILAN. KERALA
- GUJART GOLDCOIN, RAJKOT, GUJRAT
- BOSS PROFILES, KARAIKAL, PANDICHERI
- JOYTI CERAMICS, NASIK
- SARVNA CERAMICS, CHENNAI
- DECORA GROUP, RAJKOT, GUJRAT
- AHSAPURNA GROUP, GUJRAT
- MADHUMATI TILES & MADHUMATI CERAMICS- BANGLADESH,
- PUREBOND-UK,
- NYCER LIMITED, VADALUR, TAMILNADU
- JAQUAR & CFO PVT LTD, GUJRAT